

SCHMEISER®
RIPPERS & ROLLERS
ASSEMBLY & PARTS
MANUAL



3pt. models
Pull Type model
Finish Chisel
Crumbler
Down Pressure Roller™

S-Series™, C-Series™ & V-Series™
P-Series™
SFC
CR
DPR

T. G. SCHMEISER CO., INC.
P.O. BOX 1047 FRESNO, CA 93714-1047
(559) 268-8128 FAX (559) 268-3279
www.tgschmeiser.com

VERSION 2.0
APRIL 2011

INTRODUCTION

Your Schmeiser Ripper™ is designed to give you many years of dependable service. This manual has been prepared to instruct you in the safe and efficient operation of this machine. Read and study it thoroughly. Follow all instructions carefully.

Should your Ripper require replacement parts, go to your Schmeiser® dealer. Always order genuine Schmeiser replacement parts.

It is important that you complete and send in your Warranty Card because it is not valid unless it is on file at Schmeiser. If you need information not contained in this manual, contact your Schmeiser dealer.

This manual covers the following Schmeiser Ripper and Roller models: S-Series, C-Series, V-Series, P-Series, CR and DPR. Use the table of contents as a guide to locate the proper information for your selected model.

Space has been provided below for you to record the model number and serial number of your Schmeiser Ripper. Be sure to bring this information with you to your dealer when ordering parts or attachments for your Ripper.

Thank you for buying a Schmeiser Ripper.

SERIAL NUMBER _____

MODEL NUMBER _____

DATE PURCHASED _____

DEALER NAME _____

SCHMEISER® reserves the right to make improvements in design or changes in specification at any time without incurring any obligation to owners of equipment previously sold.

Copyright © 2005. T. G. Schmeiser Co., Inc. All rights reserved. This manual, or parts thereof, may not be reproduced in any form without permission.

TABLE OF CONTENTS

Introduction	2
Table of Contents.....	3
Ripper and Roller Models (covered in this manual).....	4
Safety Sheet.....	5
V-Series “Vineyard” Ripper	6
S-Series Ripper Main Frame.....	8
S-Series Gauge Leg Assembly	10
C-Series Ripper.....	11
P-Series Ripper Main Frame	12
P-Series Ripper Wheel Leg	14
P-Series Ripper Hydraulic Diagram.....	16
P-Series Ripper Hydraulic Gauging Control.....	18
36” & 38” Parabolic Shank Assembly and Point.....	19
34” L-Shank Assembly and Point.....	20
36” L-Shank Assembly and Point.....	21
Finish Chisel Ripper Main Frame	22
Finish Chisel Ripper Wheel Leg	24
Finish Chisel Ripper Shank Assembly.....	25
Crumbler.....	26
Down Pressure Roller.....	28
Limited Warranty.....	30
Maintenance & Repair Record.....	31
Notes.....	32

SCHMEISER[®] RIPPER & ROLLER MODELS



V-Series™ – 3pt. “Vineyard” Ripper



S-Series™ – 3pt. Ripper



C-Series™ – 3pt. Ripper



P-Series™ – Pull Type Ripper



Finishing Chisel



**CR – Crumbler, Spiral and
Straight Paddle Models**



DPR – Down Pressure Roller™

SAFETY

The safe operation of any machinery is an important concern to farmers and manufactures. There are obvious and hidden potential hazards involved in the operation of this implement. Carefully read and follow all safety precautions before operation. Serious injury or death may occur unless care is taken to insure the safety of both the operator and any other persons in the area.

1. Never permit anyone to ride on or walk beside the implement when moving.
2. Never permit anyone to ride on tractor when implement is being moved.
3. Before starting machine, always check area around machine to verify that all personnel are clear.
4. Never connect hydraulic lines or operate any portion of the machine unless machine is hitched to tractor.
5. Do not operate hydraulic systems when hydraulic leaks are present.
6. Before transport or unhitching, always tie back hydraulic hoses.
7. Do not exceed 2000 psi working pressure or 2500 psi maximum pressure on hydraulic system.
8. When performing operating functions, never allow anyone to be near the implement or the tractor.
9. Do not enter tractor when tractor is moving. Avoid serious injury or death from contact with rotating tires. Enter and exit the tractor only when it is completely stopped.
10. Always operate machine in a careful, controlled manner.
11. Personnel operating and working with this machinery must not wear loose, dangling or unbuttoned clothing which could tangle in machinery.
12. Be sure of water, gas, sewer, or electric line locations before operating implement.
13. When in transport, use accessory lights and devices for adequate warning to operators of other vehicles.
14. Comply with all Federal, State and local laws when traveling on public roads.
15. Use "Slow Moving Vehicle" emblem for warning vehicles approaching from the rear.
16. When transporting, remember that the implement may be wider than your tractor and extreme care must be taken to allow for safe clearance.
17. Never allow inexperienced or untrained personnel to operate the implement or tractor.
18. When using compressed air to clean implement, wear safety glasses.
19. Check all fasteners for tightness or damage before and after operation. Repair immediately if required.
20. Before transport, inspect lug bolts and tire inflation.
21. Store implement in a stable position. Insure that safety stands are extended and locked in place before detaching from tractor. Before unhitching, place chocks in front and behind all transport wheels to prevent rolling when unhitched and parked.
22. Always use two people to handle heavy, unwieldy components during assembly, installation, removal, or moving.



<u>Ref No.</u>	<u>Old Part No.</u>	<u>New Part No.</u>	<u>Description</u>	<u>Qty.</u>
1.	VRP125	VRP125	Vineyard Ripper Point Weldment	3
2.	-----	GPN-08X40R	1/2" x 2-1/2" Roll Pin	3
3.	-----	GSH-125SHS	1-1/4" Shinguard Stick	2
4.	-----	CSNC818080	1-1/8" x 5" NC Swing Bolt Gr.8	3
5.	RSB-03	RSB-03	1" x 4-1/2" NC Shear Bolt for VR	3
6.	-----	LWASHER-16	1" Lock Washer	6
7.	-----	HXNUT-16NC	1" NC Hex Nut	6
8.	-----	GPN-0872HL	1/2" x 4-1/2" Handle Lock Pin	1
9.	VR-B	VSR-00B000	Vineyard Ripper Safety Stand Weldment	1
10.	VR-C	GPN-24CA02	Pull Pin, Category II	2
11.	-----	GPN-070LYN	7/16" Lynch Pin	2
12.	-----	-----	Ripper Shank (See Table Below)	3
13.	-----	LWASHER-18	1-1/8" Lock Washer	3
14.	-----	HXNUT-18NC	1-1/8" NC Hex Nut	3

Ripper Shanks Styles for Vineyard Ripper

L-STYLE SHANKS	Part #	Description
	RLS27	1-1/4" x 27" L-Style Shank w/Chrome
	RLS31	1-1/4" x 31" L-Style Shank w/Chrome
	RLS34	1-1/4" x 34" L-Style Shank w/Chrome
STANDARD SHANKS	Part #	Description
	RSS27	1-1/4" x 27" Standard Shank w/Chrome
	RSS31	1-1/4" x 31" Standard Shank w/Chrome
	RSS34	1-1/4" x 34" Standard Shank w/Chrome
PARABOLIC SHANKS	Part #	Description
	RPS27	1-1/4" x 27" Parabolic Shank w/Chrome
	RPS31	1-1/4" x 31" Parabolic Shank w/Chrome
	RPS34	1-1/4" x 34" Parabolic Shank w/Chrome



T. G. SCHMEISER CO., INC.

VINEYARD 3PT. RIPPER

SERIAL NUMBER: _____

MODEL NUMBER: _____

CAUTION: Must replace with Schmeiser Shear Bolts only
Note: special groove on bolt head

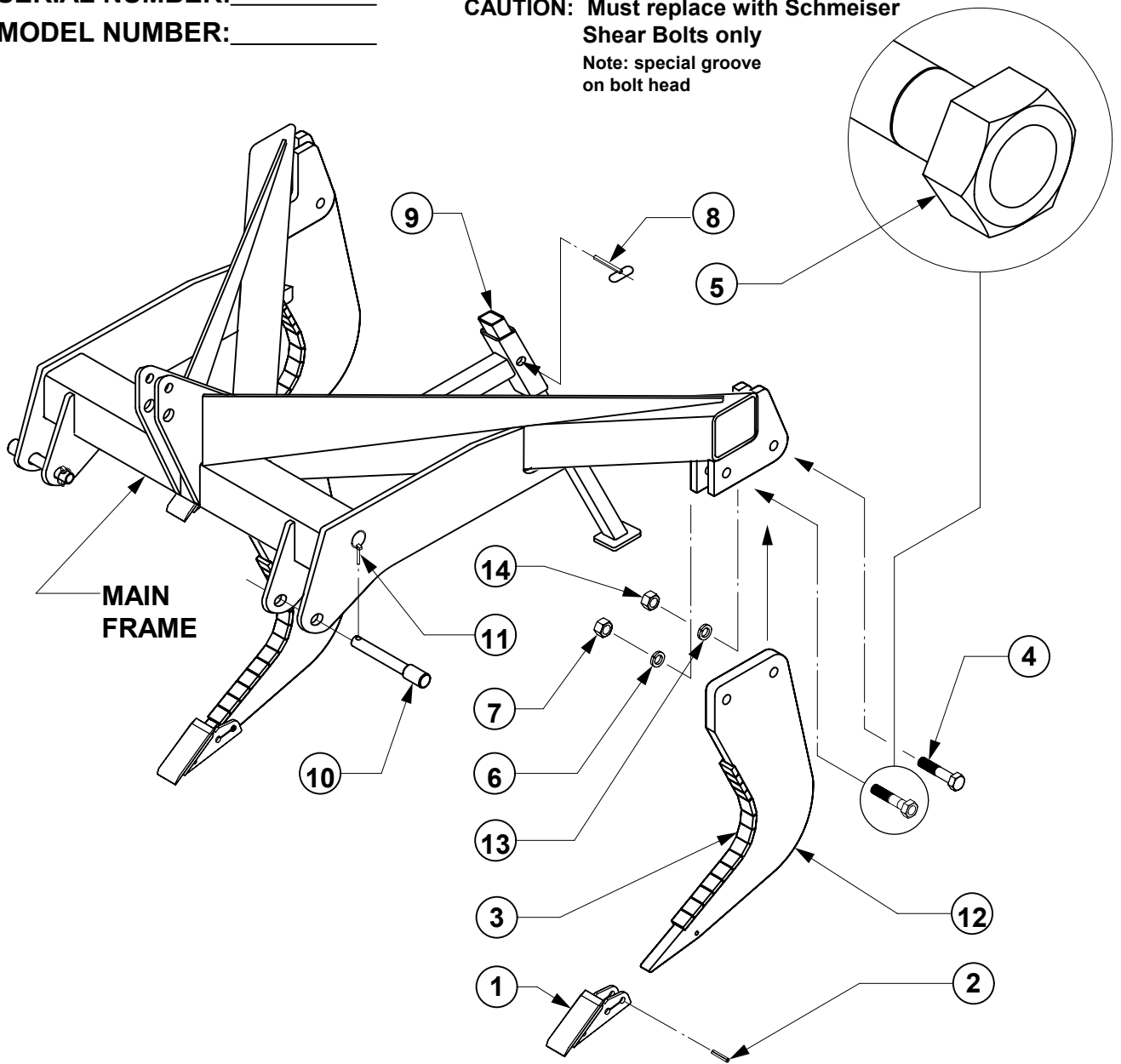

L-STYLE SHANK

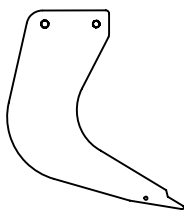

STANDARD SHANK

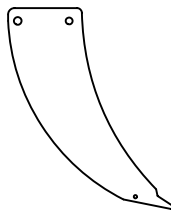

PARABOLIC SHANK

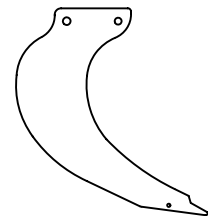

(559) 268-8128

Fax (559) 268-3279

www.tgschmeiser.com



<u>Ref No.</u>	<u>Old Part No.</u>	<u>New Part No.</u>	<u>Description</u>	<u>Qty.</u>
1.	SSR-A	SSR-00A000	Main Frame (specify spacing and shanks size & number)	1
2.	-----	-----	Shank Assembly (see Shank Assembly Drawing)	7 or 5
3.	RPP-01	GPN-31CA34	Category III & IV Bottom Pull Pin	2
4.	FHP063X0488	GPN-1056SL	5/8" x 4-7/8" Swivel Lock Hitch Pin	2
5.	RPP-02	GPN-20CA03	Category III Top Pull Pin	1
6.	FLP025X0175	GPN-040LYN	1/4" x 1-3/4" Lynch Pin	1
7.	RPP-03	GPN-28CA04	Category IV Top Pull Pin	1
8.	FPP031X0275	GPN-0536PT	5/16" x 2-3/4" PTO Pin (3 Std. + 1 Optional)	2
9.-12.	-----	-----	See Shank Assembly Drawing	---
13.	SSR-B	SSR-00B100	Gauge Leg	2
14.	SSR-C1	SSR-00C100	Steel Gauge Wheel	4
15.	SSR-D	-----	Turnbuckle - Acme Thread (see Gauge Wheel Drw)	2
16.	RSP34	RSP34	Ripper Shank Point, Small - for 1-1/4" x 34" Shanks	7 or 5
	RSP36	RSP36	Ripper Shank Point, Large - for 1-1/2" x 36" Shanks	7 or 5
18.	SSR-E2	GPN-24A201	Turnbuckle & Gauge Leg Pivot Pin	4
19.	FHB038X0300	CSNC506048	3/8" x 3" Gr. 5 Hex Bolt	4
20.	FLW038	LWASHER-06	3/8" Lock Washer	4
21.	FHN038	HXNUT-06NC	3/8" Hex Nut	4
22.	SSR-F	GWD-200DC3	Trail Hitch (Optional)	1
23.	SSR-G	GPN-28A100	Trail Hitch Pin (Optional)	1
24.	SSR-G-03	GPR-L02502	Trail Hitch Washer	1
25.	-----	RH	Rear Trail Hitch Kit (Optional) - also includes items 8, 22, 23, & 24.	1



T. G. SCHMEISER CO., INC.

S-SERIES 3PT. RIPPER

SERIAL NUMBER: _____

MODEL NUMBER: _____

**CAUTION: Must replace with
Schmeiser Shear Bolts only**
Note: special groove
on bolt head

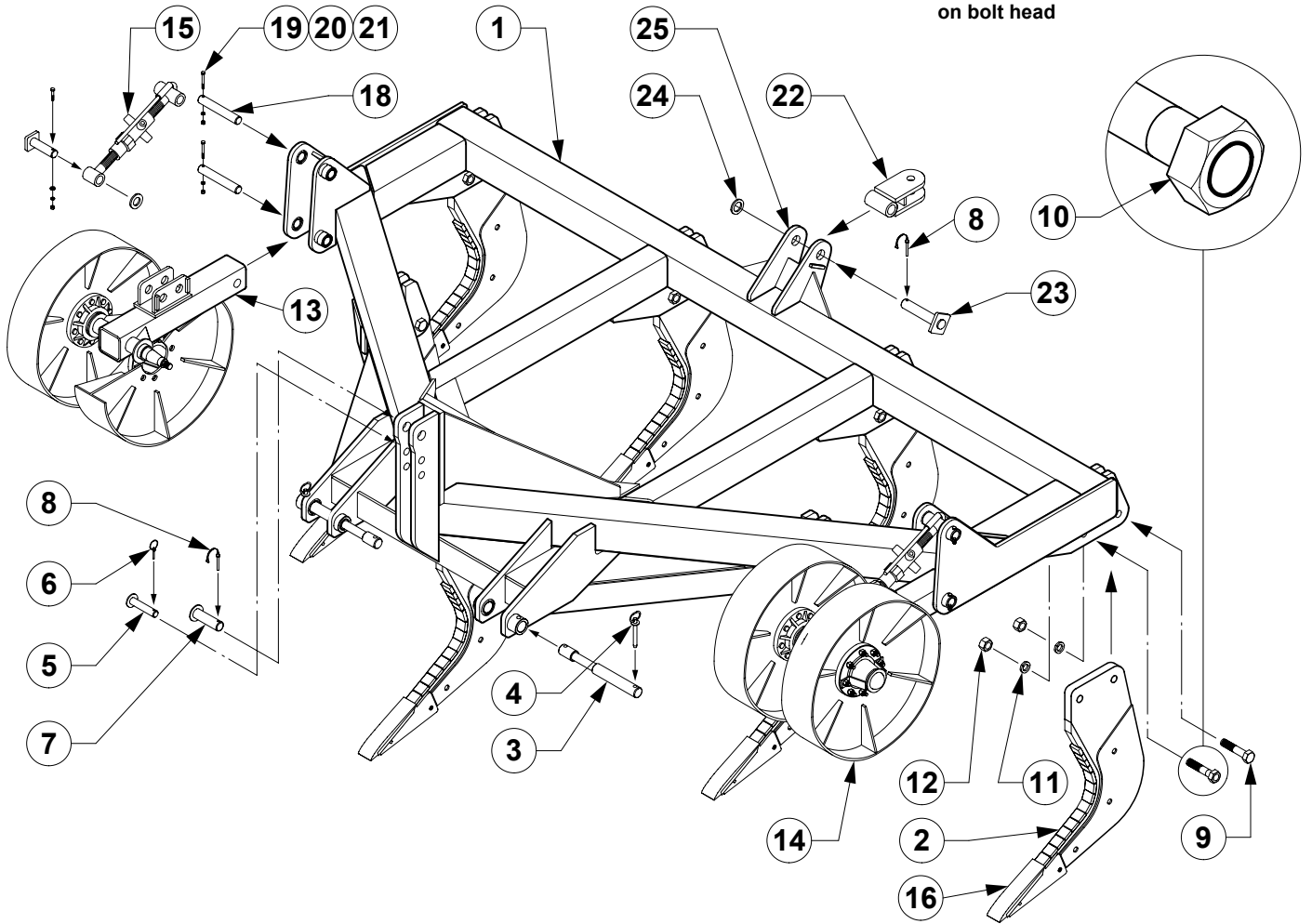

SHANK SPACING: _____

NUMBER OF SHANKS: _____

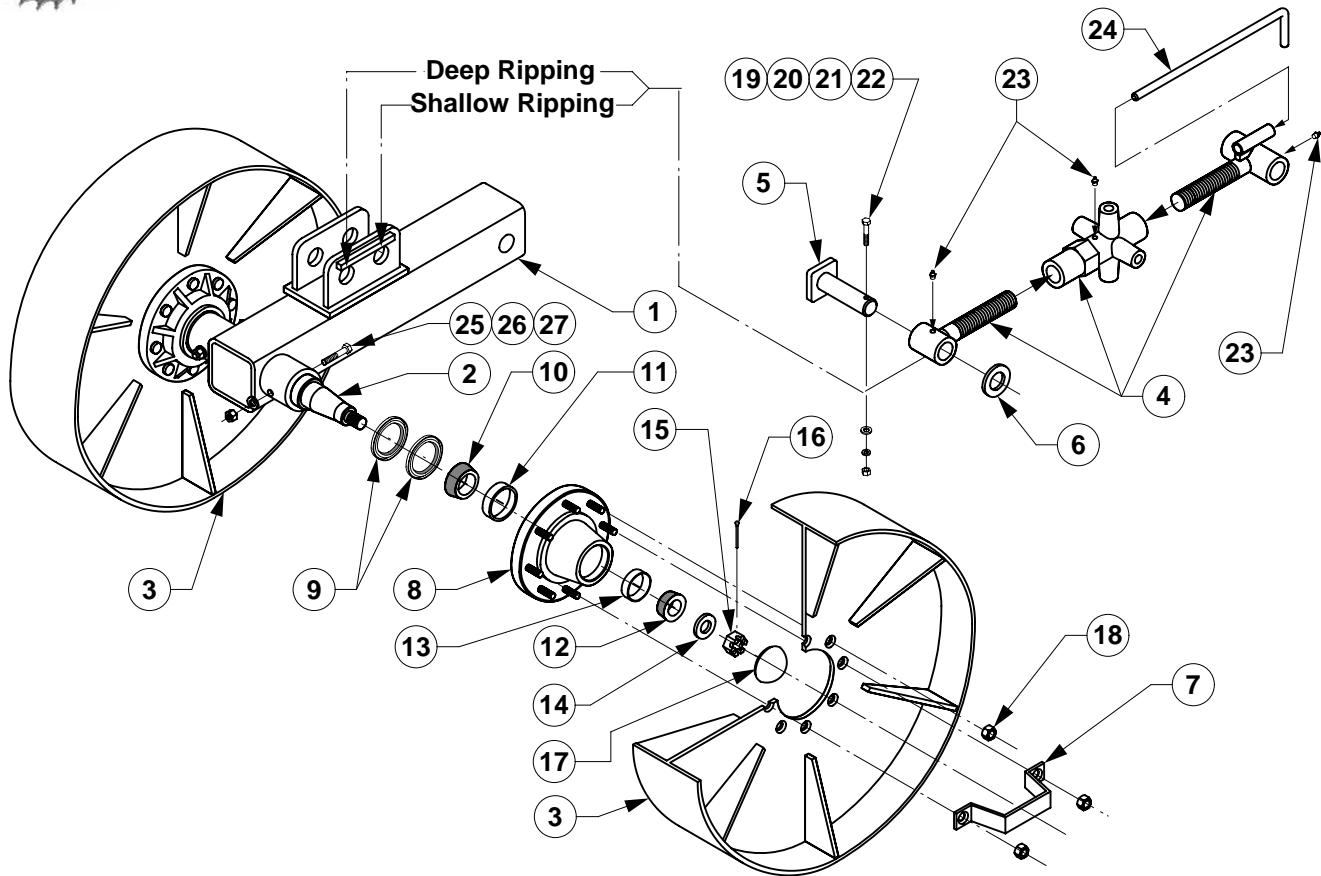

<u>Ref No.</u>	<u>Old Part No.</u>	<u>New Part No.</u>	<u>Description</u>	<u>Qty./Unit</u>
1.	SSR-B	SSR-00B100	Gauge Leg Weldment	2
2.	-----	SSR-00B104	2-3/4" Removable Spindle	2
3.	SSR-C1	SSR-00C100	Steel Gauge Wheel Weldment	4
4.	SSR-D	SSR-DTB	Turnbuckle Ass'y - ACME - Complete Kit	2
5.	SSR-E1	GPN-24A100	Turnbuckle Locking Pin	2
6.	SSR-E1-03	GPR-L02501	Turnbuckle Washer	2
7.	SSR-B2	SSR-00B200	Hub Cap Retainer	4
8.	SSR-B3	GHB-8X8XHZ	8 on 8 XHVV Hub Ass'y w/ Bearings and 2 Grease Seals	4
9.	SSR-B3-02	GHB-8XXGSL	Grease Seal (2 per Hub required)	8
10.	-----	GHB-8XXICN	Inner Bearing Cone for 8 on 8 XHVV Hub	4
11.	-----	GHB-8XXIRC	Inner Bearing Cup for 8 on 8 XHVV Hub	4
12.	-----	GHB-8XXOCN	Outer Bearing Cone for 8 on 8 XHVV Hub	4
13.	-----	GHB-8XXORC	Outer Bearing Cup for 8 on 8 XHVV Hub	4
14.	SSR-B3-03	GSP-16SPWA	1" Dia. Spindle Flat Washer	4
15.	SSR-B3-04	GSP-16CANT	1" Dia. Spindle Castle Nut	4
16.	FCP018X0200	GPN-03X32C	3/16" x 2" Cotter Pin	4
17.	SSR-B3-05	GHB-8XXCAP	Hub Cap	4
18.	SSR-B3-06	WHN-10NFWN	Hub Lug Nuts 5/8" NF for 8X8 XHVV Hub	32
19.	FHB031X0200	CSNC505032	5/16" X 2" Gr. 5 Hex Bolt	2
20.	FFW031	FWASHER-05	5/16" Flat Washer	2
21.	FLW031	LWASHER-05	5/16" Lock Washer	2
22.	FHN031	HXNUT-05NC	5/16" Hex Nut	2
23.	FGZ-THD	GMB-ZERKTH	Threaded Grease Zerk	6
24.	DPR-D-07	GPR-R06301	Turnbuckle Crank Rod	2
25.	-----	CSNC509072	9/16" X 4-1/2" NC Cap Screw	4
26.	-----	LWASHER-09	9/16" Lock Washer	4
27.	-----	HXNUT-09NC	9/16" NC Hex Nut	4



SERIAL NUMBER: _____

MODEL NUMBER: _____

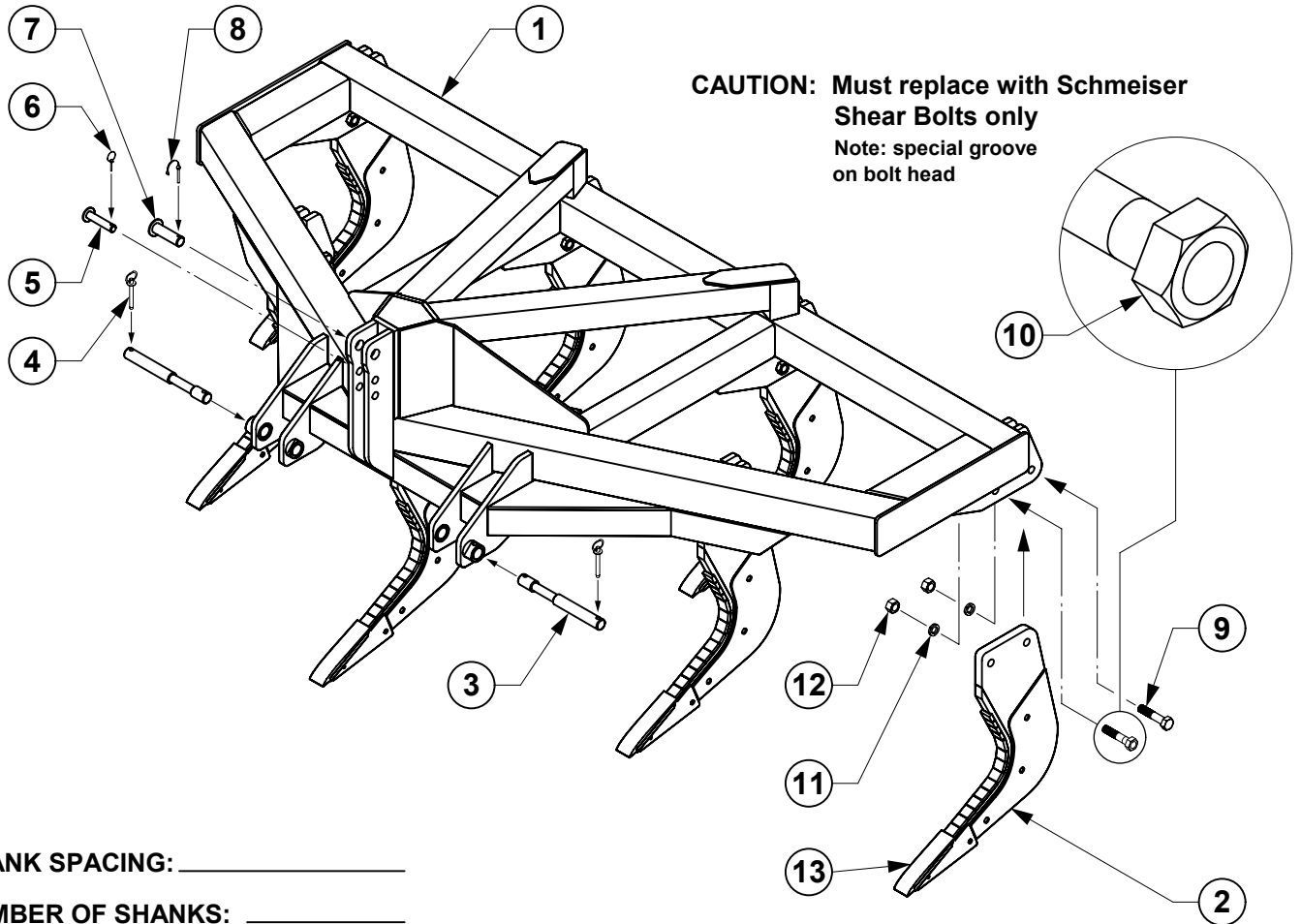

SHANK SPACING: _____

NUMBER OF SHANKS: _____

Ref No.	Old Part No.	New Part No.	Description	Qty.
1.	CSR-A	CSR-00A000	Main Frame (specify spacing and shanks size & number)	1
2.	-----	-----	Shank Assembly (see Shank Assembly Drawing)	7 or 5
3.	RPP-01	GPN-31CA34	Category III & IV Bottom Pull Pin	2
4.	FHP063X0488	GPN-1056SL	5/8" x 4-7/8" Swivel Lock Hitch Pin	2
5.	RPP-02	GPN-20CA03	Category III Top Pull Pin	1
6.	FLP025X0175	GPN-040LYN	1/4" Lynch Pin	1
7.	RPP-03	GPN-28CA04	Category IV Top Pull Pin	1
8.	FPP031X0275	GPN-0536PT	5/16" x 2-3/4" PTO Pin	1
9-12.	-----	-----	See Shank Assembly Drawing	----
13.	RSP34	RSP34	Ripper Shank Point, Small - for 1-1/4" x 34" Shanks	7 or 5
	RSP36	RSP36	Ripper Shank Point, Large - for 1-1/2" x 36" Shanks	7 or 5

Note: Down Pressure Roller is required to complete all C-series Rippers for gauging depth.



<u>Ref No.</u>	<u>Old Part No.</u>	<u>New Part No.</u>	<u>Description</u>	<u>Qty.</u>
1.	PSR-A	PSR-00ACA3	Clevis Hitch Category 3	1
		PSR-00ACA4	Clevis Hitch Category 4	1
2.	PSR-B	PSR-00B000	Clevis Hitch Pin	1
3.	PSR-B-03	PSR-00B003	Hitch Pin Stop Collar	1
4.	TGS-JS8000	GJK-5KSW00	5000# Cap. Side-winding Jack Stand	1
5.	-----	PSR-00D000	Main Frame Non-Detachable	1
		PSR-00D200	Main Frame Detachable (Shown)	1
7.	-----	PSR-00E000	See Gauge Leg Assembly	2
8.	PSR-E2	PSR-00E200	Hydraulic Cylinder Mast Pin	2
9.	PSR-E3-A	PSR-00E301	Hydraulic Cylinder Gauge Leg Pin	1
10.	PSR-E3-B	PSR-00E302	Hydraulic Cylinder Gauge Leg Depth Control Pin	1
11.	PSR-F6	CWD	1800# Counter Weight for D.P. Roller (Optional)	1
	PSR-F3	CWC	900# Counter Weight for Crumbler (Optional)	1
12.	-----	PSR-00G000	See Hydraulic Depth Control Assembly Page	1
13.	-----	-----	See Shank Assembly Page	7 or 5
14.	HC5X24W	GHC-50240W	5 x 24 Welded Hydraulic Cylinder	2
15.	TGS-HPR-23	VFLOWDIV02	Geared Flow Divider	1
16.	TGS-YEJ	VORIFICER1	P.O. Check Valve	2
17.	TGS-RFC	VSTRCONTR1	Remote Flow Control Valve	1
18.	FHB125X1000	CSNC820160	1-1/4" X 10" Gr. 8 Hex Bolt (For Detachable Units Only)	3
19.	FHB150X1100	CSNC824176	1-1/2" X 11" Gr. 8 Hex Bolt (For Detachable Units Only)	4
20.	RSP34	RSP34	Ripper Shank Point, Small - for 1-1/4" x 34" Shanks	7 or 5
	RSP36	RSP36	Ripper Shank Point, Large - for 1-1/2" x 36" Shanks	7 or 5



SERIAL NUMBER: _____
MODEL NUMBER: _____

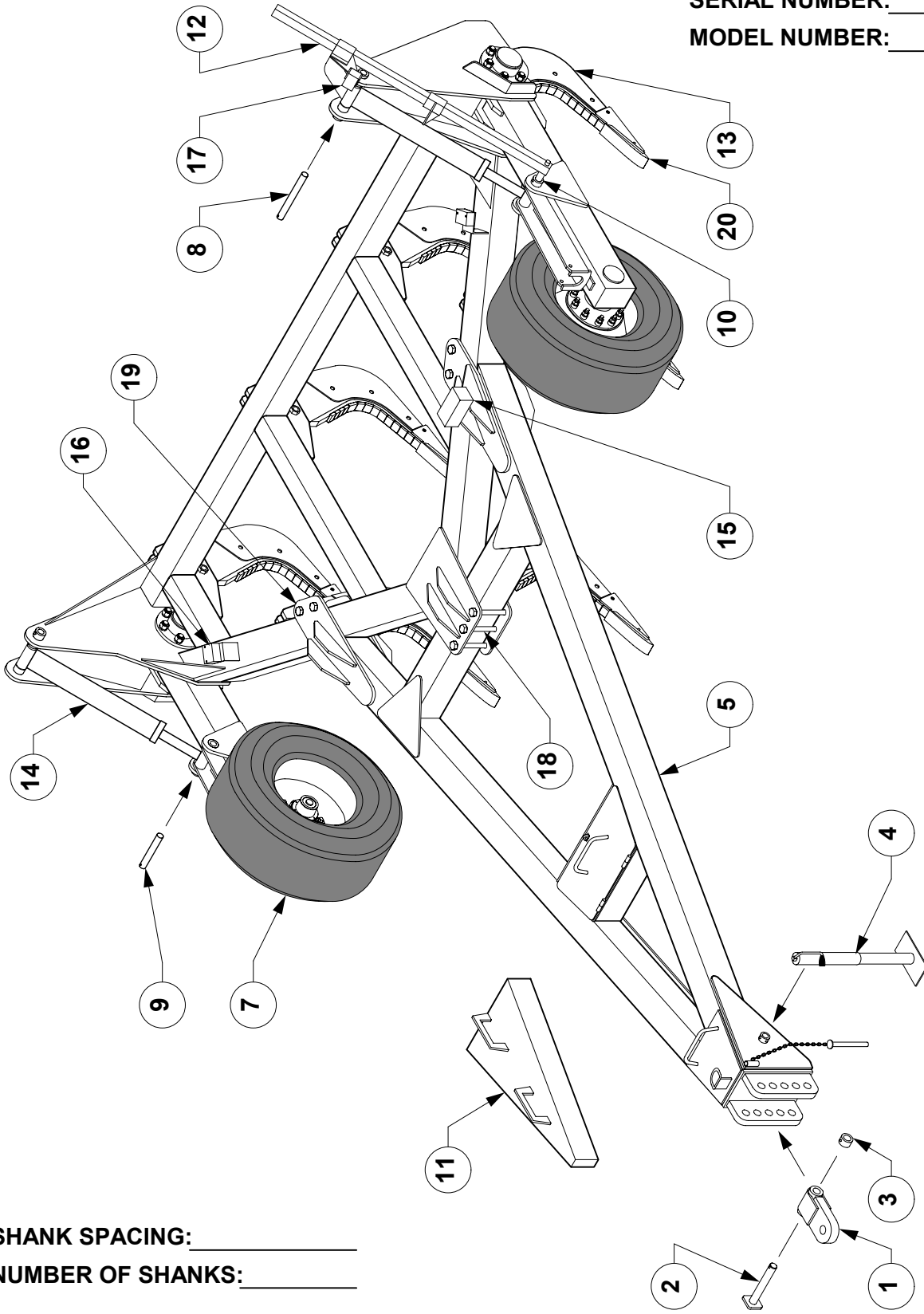

SHANK SPACING: _____
NUMBER OF SHANKS: _____



<u>Ref No.</u>	<u>Part No.</u>	<u>Description</u>	<u>Qty. per Leg</u>
1.	PSR-00D100	Gauge Leg	1
2.	GWD-524LB1	Lockout Bar for 5" x 24" Hydraulic Cylinder	1
3.	PSR-00E301	Hydraulic Cylinder Gauge Leg Pin	1
4.	GBR-8088GB	5" X 5-1/2" Garmax Bearing	2
5.	PSR-00D300	Bearing Housing	2
6.	CSNC516048	1" X 3" Gr. 5 NC Cap Screw	10
7.	LWASHER-16	1" Lock Washer	10
8.	HXNUT-16NC	1" NC Hex Nut	10
9.	GBR-46305S	Grease Seal	1
10.	GHB-10XICN	Inner Bearing Cone	1
11.	GHB-10XIRC	Inner Bearing Cup	1
13*	GHB-10XSTUDL(R)	3/4" Shoulder Stud LH (RH) 3" Shoulder	10
	GHB-10XSTD4L(R)	3/4" Shoulder Stud LH (RH) 4" Shoulder	10
14.	GHB-10XORC	Outer Bearing Cup	1
15.	GHB-10XOCN	Outer Bearing Cone	1
16.	GSP-57SPWA	Spindle Washer	1
17.	GSP-57ISBN	Inner Spindle Bearing Nut	1
18.	GSP-57ISLW	Inner Lock Washer - Indexing	1
19.	GSP-57OSLW	Outer Lock Washer - Tab	1
20.	GSP-57OSBN	Outer Spindle Nut	1
22.	GHB-10XCGA	Oil Bath Cap and Gasket Assembly	1
23.	GWT-2212WL	22.5 x 12.25 10 on 11.25 Wheel	1
24.	GWT-65R22C	385/65R22.5 Casing	1
25.	GWT-65R22M	385/65R22.5 WB Tire Mounted	1
26.	GHB-10XLN12L	3/4" Lug Nut LH Thread	10
	GHB-10XLN12R	3/4" Lug Nut RH Thread	10
27.	HXNUTC12NC	3/4" Class "C" NC Hex Lock Nut	10
	GHB-10XHUB	10-Stud 20K Capacity Hub with Cups and Lugs (includes items 11, 13, 14, 26, 27)	1
	GHB-10X20K	10-Stud 20K Capacity Hub Complete (includes items 10, 11, 13, 14, 15, 22, 26, 27)	1

* NOTE: Always specify LH or RH Thread and Stud Shoulder Length.

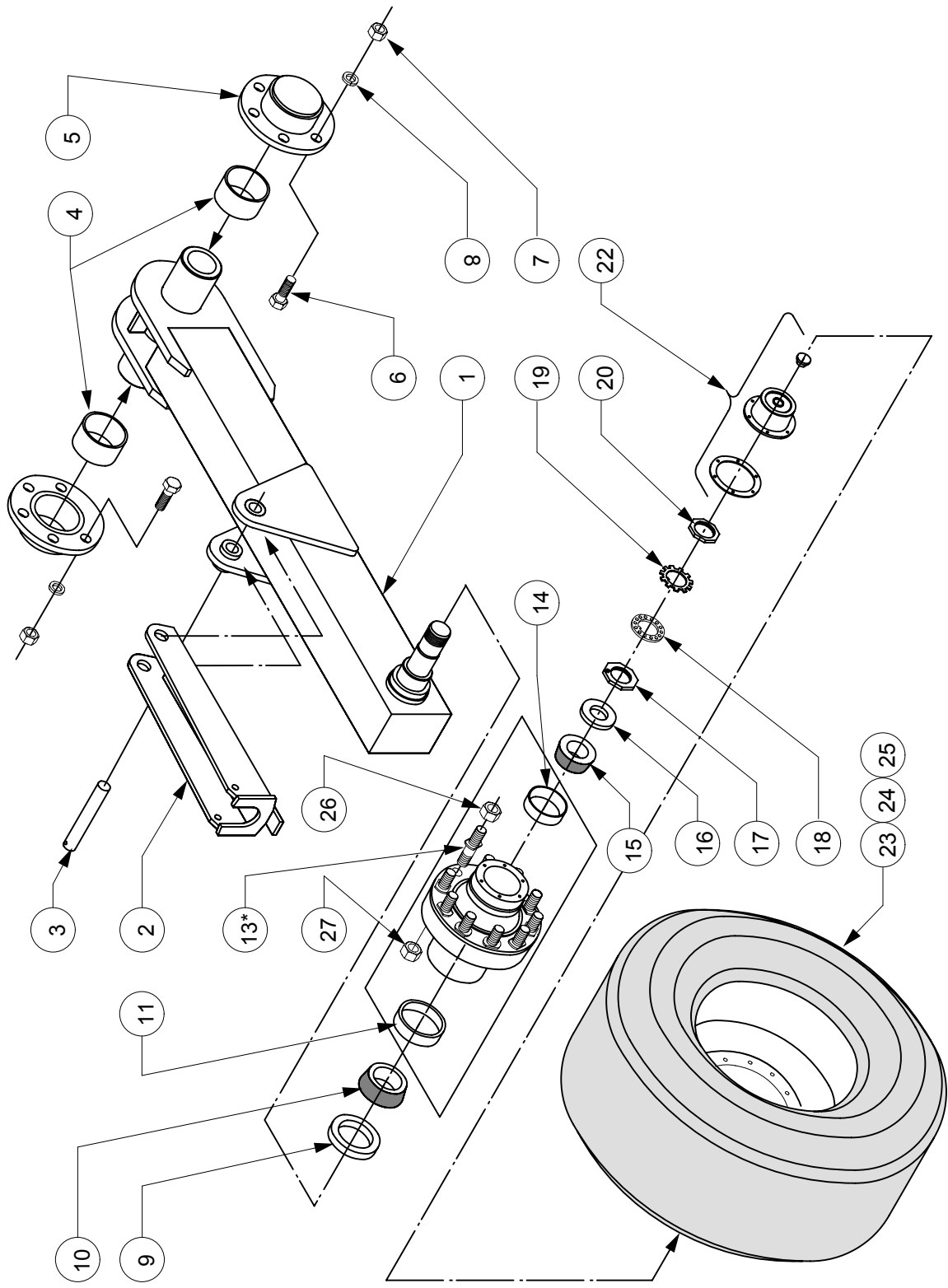



<u>Ref No.</u>	<u>New Part No.</u>	<u>Description</u>	<u>Qty.</u>
<u>FITTINGS AND VALVES (3,000 PSI CAP.)</u>			
A	FFP08000PT	FP-8 Pioneer 150 Tips	2
B	FFPT080000	FPT-8 Tee	1
C	FMPFPX90128	MP-FPX 90° 12-8 Elbow	4
D	FMJMJMBT08	MJ-MJ-MBT-8 Tee	1
E	FMBFJX088C	MB - FJX - 8 - 8 Coupling	1
F	FMBFPX88C	MB-FPX 8-8 Coupling	3
G	FMBFPX9088	MB-FPX 90° 8-8 Elbow	6
H	FMBMJ09088	MB - MJ 90° 8 - 8 Elbow	1
I	FMBFPX90128	MB - FPX 90° - 12 - 8 Elbow	2
J	FMBFB00168	MB - FB - 16 -8 Coupling	1
K	FRBG12PLUG	RBG - 16 Plug	1
R	VORIFICER1	Orifice Restrictor 1/8	1
S	VFLOWDIV02	Geared Flow Divider	1
T	VSTRCONTR1	Remote Flow control Valve	1
U	VCHECKDTH1	Check Valve MJ-MJ-8-8	1
V	VCHECKPO01	Check Valve PO	2

HYDRAULIC CYLINDERS

GHC-50240W	5" x 24" Welded Hydraulic Cylinder	2
------------	------------------------------------	---

6M3K HOSE (3,000 PSI CAP.)

#1	H0176G8FJX90S	6G/8FJX90S - 6G/8FJX90S Hose 17-1/2" Long 90° Stems point in same direction	1
----	---------------	--	---

8M3K MTF HOSES (3,000 PSI CAP.)

#2	H0428MP8MP	8MP - 8MP Hose 42" Long	2
#3	H1228MP8MP	8MP - 8MP Hose 122" Long	1
#4	H3368MP8FJX	8MP - 8FJX Hose 336" Long	1
#5	H2478MP8MP	8MP - 8MP Hose 247" Long	1
#6	H0888MP8FJX90S	8MP - 8FJX90S Hose 88" Long	1
#7	H1188MP8MP	8MP - 8MP Hose 118" Long	1
#8	H0388MP8MP	8MP - 8MP Hose 38" Long	4



NOTE: PLACE RESTRICTOR (R) IN FLOW CONTROL VALVE WITH CHANNEL GROOVE FACING OUT.

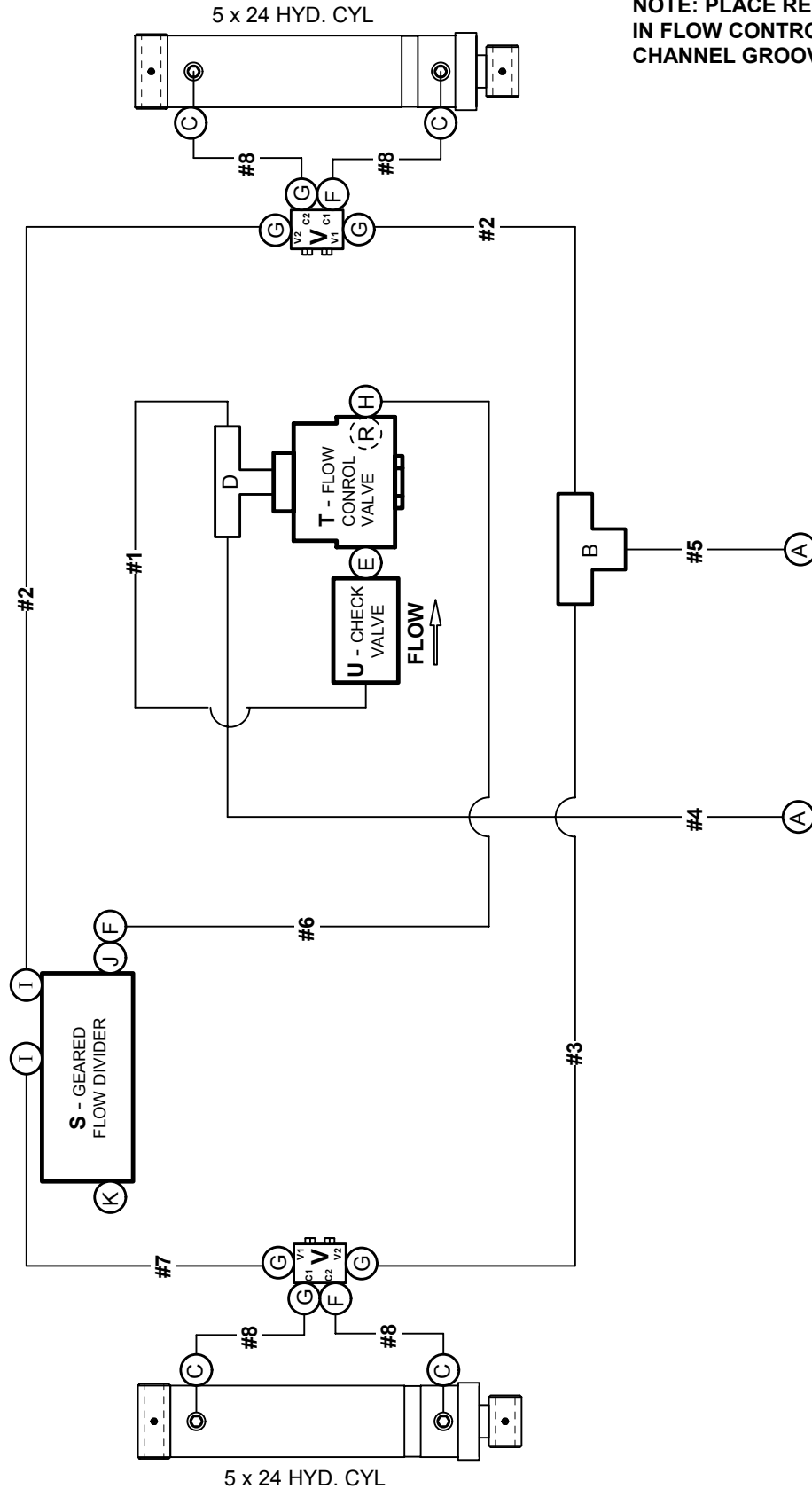

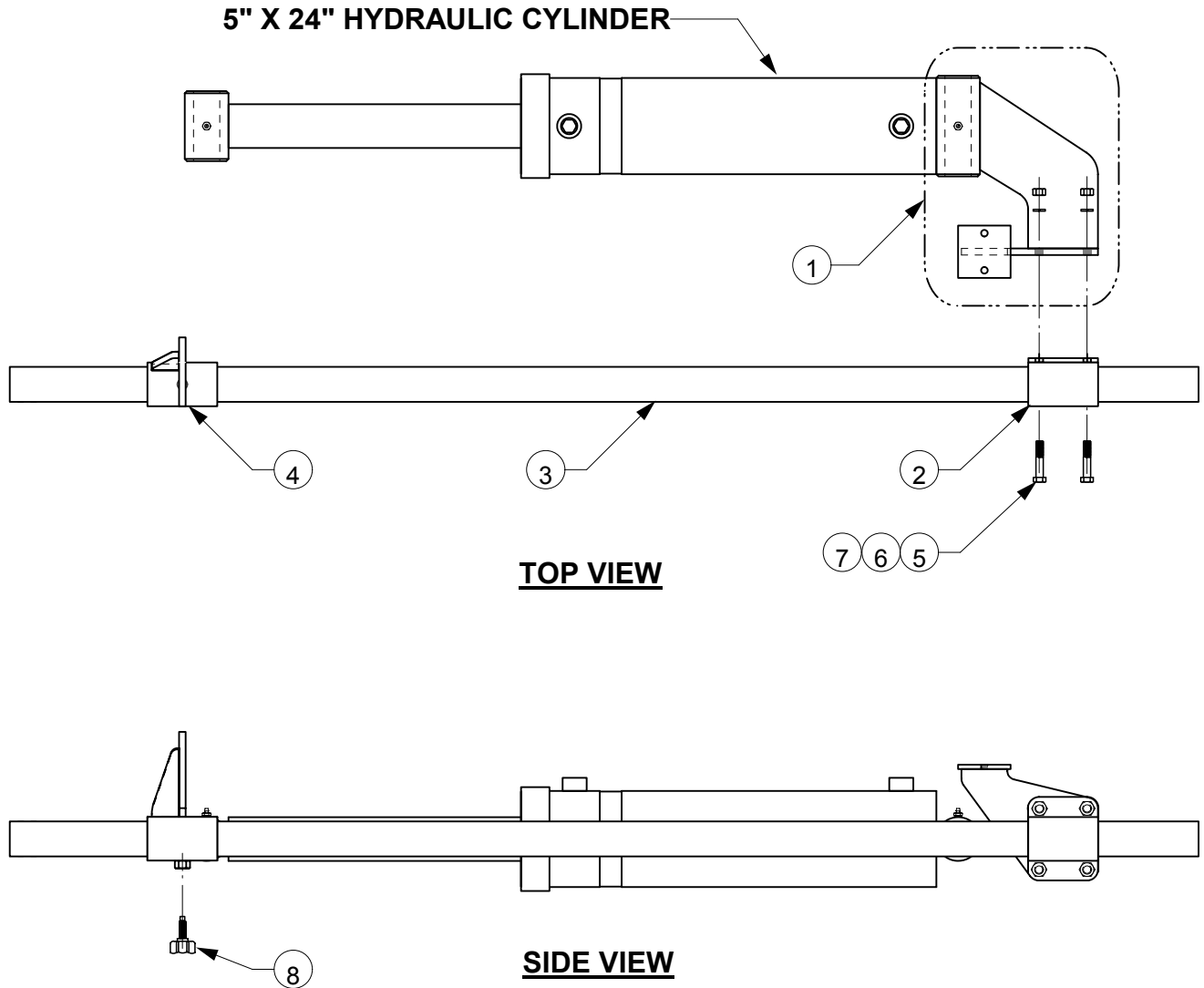

<u>Ref No.</u>	<u>Old Part No.</u>	<u>New Part No.</u>	<u>Description</u>	<u>Qty.</u>
1.	PSR-G1	PSR-00G100	PSR HGC Valve Mount & Guide Sleeve Mount	1
2.	PSR-G2	PSR-00G200	PSR HGC Guide Weldment	1
3.	PSR-G3	PSR-00G300	PSR HGC Slide Bar Weldment	1
4.	PSR-G4	PSR-00G400	PSR HGC Adjustment Stop Weldment	1
5.	-----	CSNC506024	3/8" X 1-1/2" NC Cap Screw Gr.5 ZP	4
6.	-----	LWASHER-06	3/8" Lock Washer	4
7.	-----	HXNUT-06NC	3/8" NC Hex Nut	4
8.	-----	GMB-KNOB01	PSR HGC Clamping Knob	1

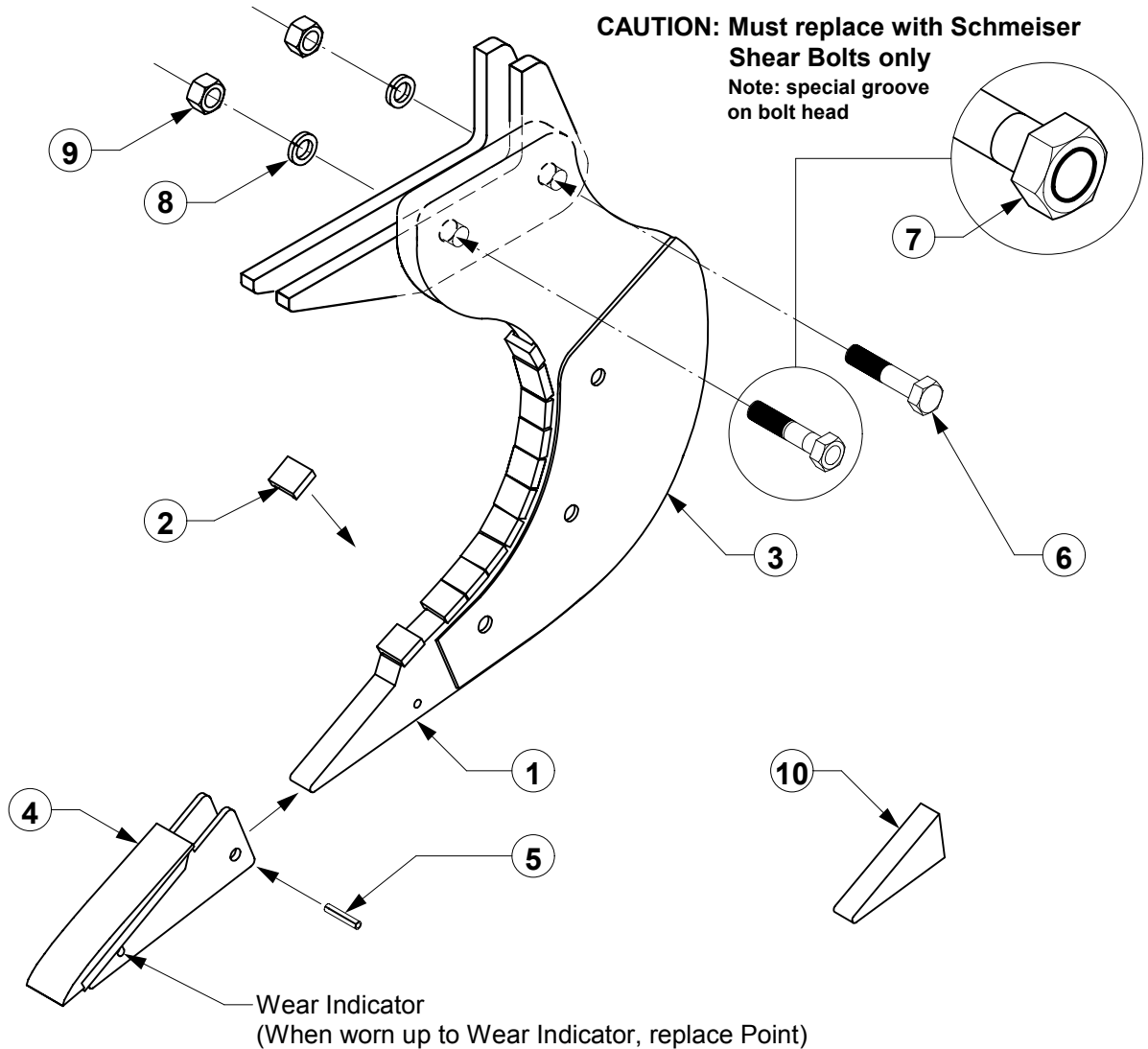

<u>Ref No.</u>	<u>Part No.</u>	<u>New Part No.</u>	<u>Description</u>
1.	RPS36	GSH-36RPS1	1-1/2" x 36" Parabolic Shank only (less Chrome)
	RPS38	GSH-38RPS1	1-1/2" x 38" Parabolic Shank only (less Chrome)
		RPS36	1-1/2" x 36" Parabolic Shank w/ Chrome
		RPS38	1-1/2" x 38" Parabolic Shank w/ Chrome
		RPS36WG	1-1/2" x 36" Parabolic Shank w/ Chrome and Wear Guards
		RPS38WG	1-1/2" x 38" Parabolic Shank w/ Chrome and Wear Guards
2.	3PR-150	GSH-150SHS	(2) 1-1/2" Chrome Sticks (each stick has 7 pcs)
3.	PWG	PWG	Parabolic Shank Wear Guard - 2 plates (Optional)
4.	RSP36	RSP36	1-1/2" x 12-1/4" Shank Point
5.	FRP050X0250	GPN-08X40R	1/2" x 2-1/2" Roll Pin - zinc plated
6.	RPB-01	CSNC820088	1-1/4" x 5-1/2" Gr. 8 Pivot Hex Bolt
7.	RSB-01	RSB-01	1-1/4" x 5-1/2" Dual Score Gr. 5 Shear Bolt
8.	FLW125	LWASHER-20	1-1/4" Lock Washer
9.	FHN125	HXNUT-20NC	1-1/4" Hex Nut
10.	RLS36-RTS	RLS36-RTS	1-1/2" x 7" Shank Replacement Tip

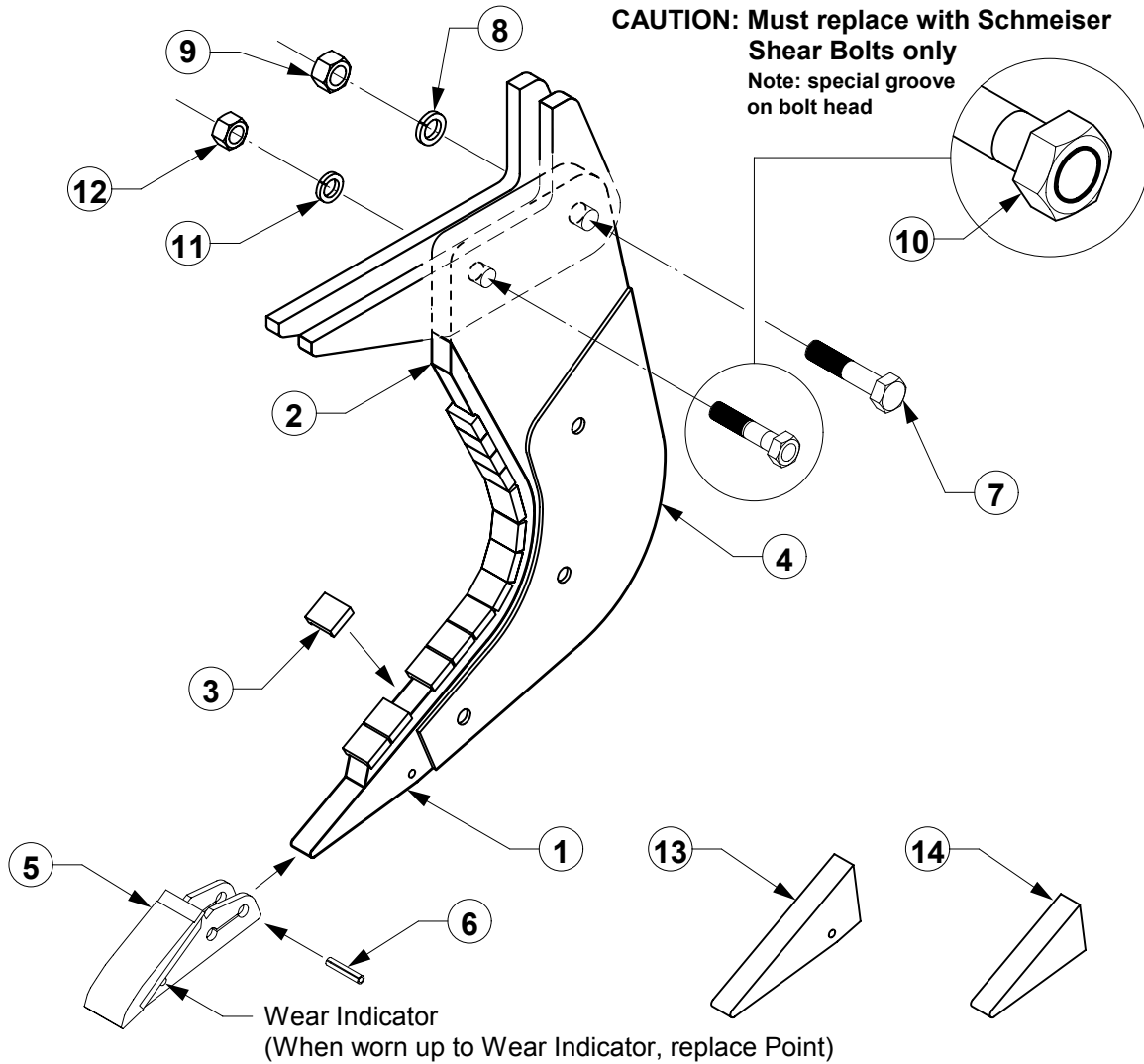

<u>Ref No.</u>	<u>Old Part No.</u>	<u>New Part No.</u>	<u>Description</u>
1.	RLS34-01 RLS34 -----	GSH-34RLS1 RLS34 RLS34WG	1-1/4" x 34" L-Shank 1-1/4" x 34" L-Shank with Shin and Chrome 1-1/4" x 34" L-Shank w/Shin, Chrome, and Wear Guards
2.	RLS34-02	GSH-34RLS2	1-1/4" L-Shank Shin
3.	3PR-125	GSH-125SHS	(2) 1-1/4" Chrome Sticks (each stick has 7 pcs.)
4.	LWG	LWG	L-Shank Wear Guard - pair (Optional)
5.	RSP34	RSP34	1-1/4" x 8" Shank Point
6.	FRP050X0250	GPN-08X40R	1/2" x 2-1/2" Roll Pin - zinc plated
7.	RPB-02	CSNC818080	1-1/8" x 5" Gr. 8 Pivot Hex Bolt
8.	FLW113	LWASHER-18	1-1/8" Lock Washer
9.	FHN113	HXNUT-18NC	1-1/8" Hex Nut
10.	RSB-02	RSB-02	1" x 5" Dual Score Gr. 5 Shear Bolt
11.	FLW100	LWASHER-16	1" Lock Washer
12.	FHN100	HXNUT-16NC	1" Hex Nut
13.	RLS34-RTL	RLS34-RTL	1-1/4" x 11" Shank Replacement Tip
14.	RLS34-RTS	RLS34-RTS	1-1/4" x 7" Shank Replacement Tip



CAUTION: Must replace with Schmeiser Shear Bolts only
 Note: special groove on bolt head

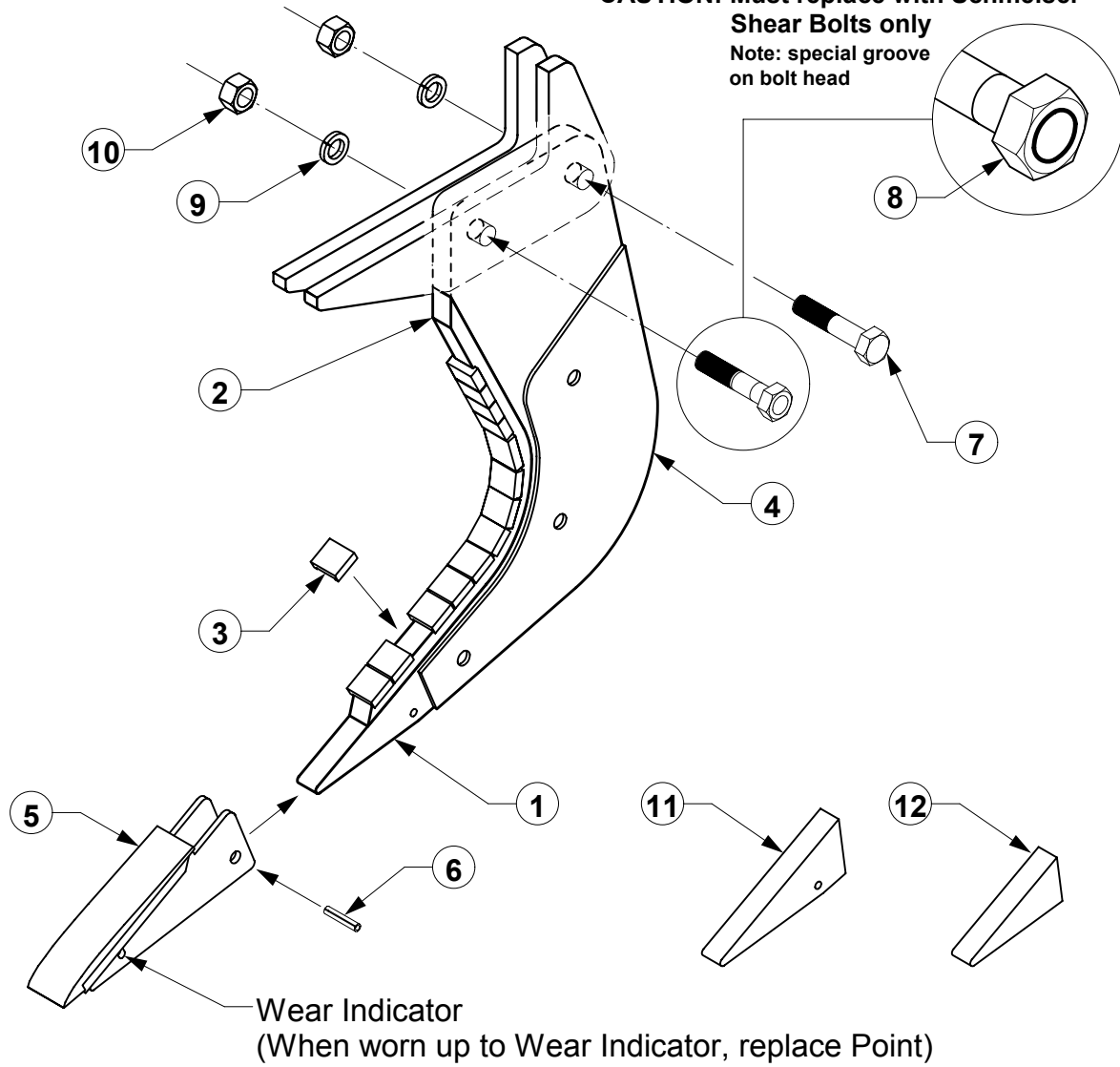

<u>Ref No.</u>	<u>Part No.</u>	<u>New Part No.</u>	<u>Description</u>
1.	RLS36-01	GSH-36RLS1	1-1/2" x 36" L-Shank
	RLS36	RLS36	1-1/2" x 36" L-Shank with Shin and Chrome
		RLS36WG	1-1/2" x 36" L-Shank w/Shin, Chrome, and Wear Guards
2.	RLS36-02	GSH-36RLS2	1-1/2" L-Shank Shin
3.	3PR-150	GSH-150SHS	(2) 1-1/2" Chrome Sticks (each stick has 7 pcs)
4.	LWG	LWG	L-Shank Wear Guard - pair (Optional)
5.	RSP36	RSP36	1-1/2" x 12-1/4" Shank Point
6.	FRP050X0250	GPN-08X40R	1/2" x 2-1/2" Roll Pin - zinc plated
7.	RPB-01	CSNC820088	1-1/4" x 5-1/2" Gr. 8 Pivot Hex Bolt
8.	RSB-01	RSB-01	1-1/4" x 5-1/2" Dual Score Gr. 5 Shear Bolt
9.	FLW125	LWASHER-20	1-1/4" Lock Washer
10.	FHN125	HXNUT-20NC	1-1/4" Hex Nut
11.	RLS36-RTL	RLS36-RTL	1-1/2" x 11" Shank Replacement Tip
12.	RLS36-RTS	RLS36-RTS	1-1/2" x 7" Shank Replacement Tip



<u>Ref No.</u>	<u>Part No.</u>	<u>Description</u>	<u>Qty.</u>
1.	FCS-00A000	Main Frame (specify size)	1
2.	-----	Finish Chisel Shank Ass'y (see Finish Chisel Shank Drawing)	varies
3.	GPN-31CA34	Category III & IV Bottom Pull Pin	2
4.	GPN-1056SL	5/8" x 4-7/8" Swivel Lock Hitch Pin	2
5.	GPN-20CA03	Category III Top Pull Pin	1
6.	GPN-040LYN	1/4" x 1-3/4" Lynch Pin	1
7.	GPN-28CA04	Category IV Top Pull Pin	1
8.	GPN-0536PT	5/16" x 2-3/4" PTO Pin (3 Std. + 1 Optional)	2
9.-11	-----	See Finish Chisel Shank Drawing	---
12.	GPN-24A201	Turnbuckle & Gauge Leg Pivot Pin	4
13.	SSR-00B100	Gauge Leg Weldment	2
14.	GWT-121614	12.5" X 16" Wheel with Tire	2
15.	SSR-DTB	Turnbuckle Assembly - Acme Thread (see Gauge Leg Drw)	2
16.	CSNC506048	3/8" x 3" Gr. 5 Hex Bolt	4
17.	LWASHER-06	3/8" Lock Washer	4
18.	HXNUT-06NC	3/8" Hex Nut	4
19.	FCU-00H000	Trail Hitch Mount Weldment (Optional)	1
20.	CSNC516040	1" x 2-1/2" Gr. 5 Hex Bolt	4
21.	LWASHER-16	1" Lock Washer	4
22.	HXNUT-16NC	1" Hex Nut	4
23.	GWD-200DC3	Trail Hitch (Optional)	1
24.	GPN-28A100	Trail Hitch Pin (Optional)	1
25.	GPR-L02502	Trail Hitch Washer	1
26.	FCU-00H008	Trail Hitch Mount Hinge Pin	1
27.	GPN-05X40R	5/16" X 2-1/2" Roll Pin	1
	SFC-RH3B	Finish Chisel Trail Hitch Kit (includes items 8, 19 through 27)	

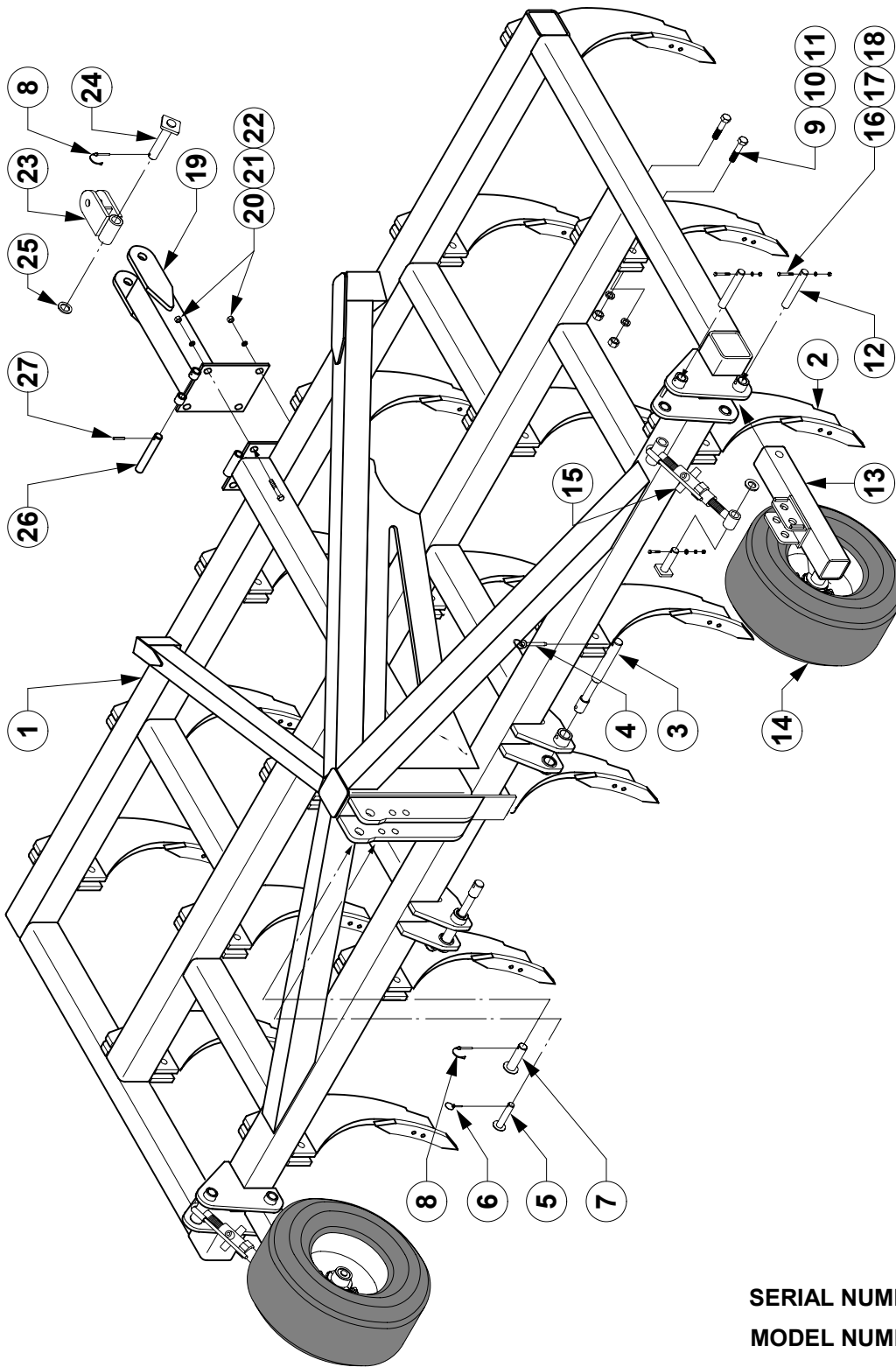

SERIAL NUMBER: _____

MODEL NUMBER: _____

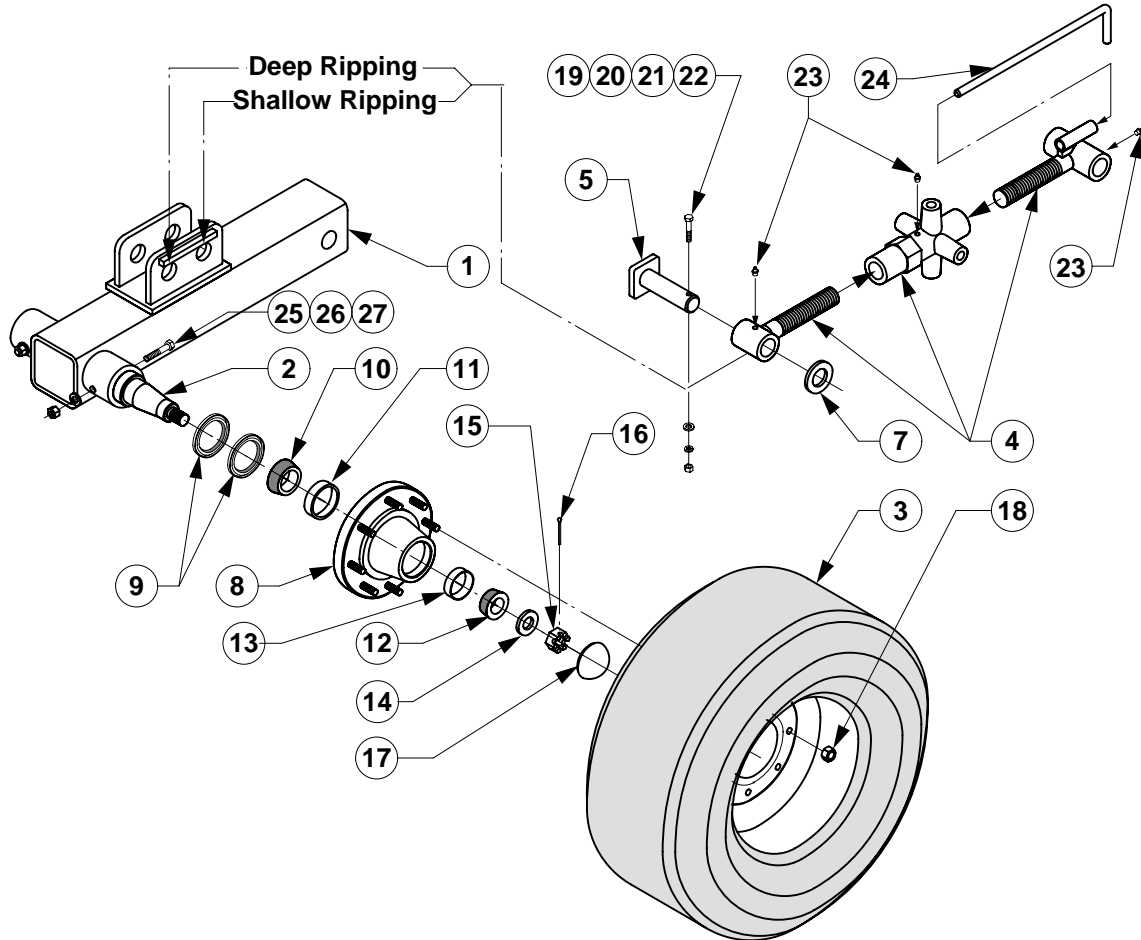

Ref No.	New Part No.	Description	Qty./Unit
1.	SSR-00B100	Gauge Leg Weldment	2
2.	FTB4-00M300	2-3/4" Removable Spindle	2
3.	GWT-121614	12.5" X 16" Wheel with Tire	2
4.	SSR-DTB	Turnbuckle Ass'y - ACME - Complete Kit	2
5.	GPN-24A100	Turnbuckle Locking Pin	2
7.	GPR-L02501	Turnbuckle Washer	2
8.	GHB-8X8XHZ	8 on 8 XHVV Hub Ass'y w/ Bearings and 2 Grease Seals	2
9.	GHB-8XXGSL	Grease Seal (2 per Hub required)	4
10.	GHB-8XXICN	Inner Bearing Cone for 8 on 8 XHVV Hub	2
11.	GHB-8XXIRC	Inner Bearing Cup for 8 on 8 XHVV Hub	2
12.	GHB-8XXOCN	Outer Bearing Cone for 8 on 8 XHVV Hub	2
13.	GHB-8XXORC	Outer Bearing Cup for 8 on 8 XHVV Hub	2
14.	GSP-16SPWA	1" Dia. Spindle Flat Washer	2
15.	GSP-16CANT	1" Dia. Spindle Castle Nut	2
16.	GPN-03X32C	3/16" x 2" Cotter Pin	2
17.	GHB-8XXCAP	Hub Cap	2
18.	WHN-10NFWN	Hub Lug Nuts 5/8" NF for 8X8 XHVV Hub	16
19.	CSNC505032	5/16" X 2" Gr. 5 Hex Bolt	2
20.	FWASHER-05	5/16" Flat Washer	2
21.	LWASHER-05	5/16" Lock Washer	2
22.	HXNUT-05NC	5/16" Hex Nut	2
23.	GMB-ZERKTH	Threaded Grease Zerk	6
24.	GPR-R06301	Turnbuckle Crank Rod	2
25.	CSNC509072	9/16" X 4-1/2" NC Cap Screw	4
26.	LWASHER-09	9/16" Lock Washer	4
27.	HXNUT-09NC	9/16" NC Hex Nut	4

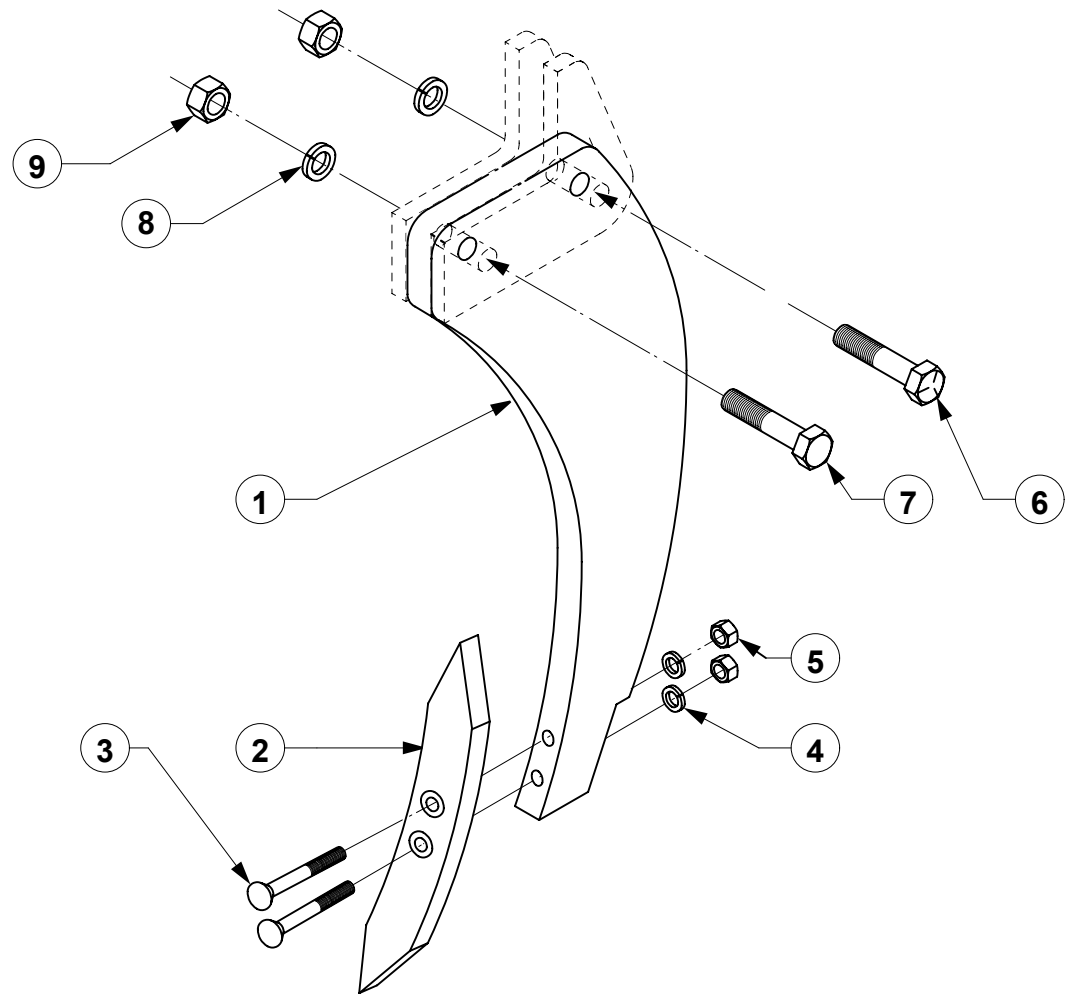

<u>Ref No.</u>	<u>Part No.</u>	<u>Description</u>
1.	GSH-125CH1	1-1/4" X 30" Finish Chisel Shank
2.	SCP0721	Regular Chisel Point
3.	PBNC-08064	1/2" X 4" NC Plow Bolt
4.	LWASHER-08	1/2" Lock Washer
5.	HXNUT-08NC	1/2" NC Hex Nut
6.	CSNC512064	3/4" X 4" Gr.5 Hex Swing Bolt
7.	CSNC212064	3/4" x 4" Gr.2 Hex Shear Bolt
8.	LWASHER-12	3/4" Lock Washer
9.	HXNUT-12NC	3/4" Hex Nut



<u>Ref No.</u>	<u>Old Part No.</u>	<u>New Part No.</u>	<u>Description</u>	<u>Qty.</u>
1.	CR-A	CRM-(00)A000	Crumbler Main Frame (Specify Size)	1
2.	CR-B	CRM-00B000	Crumbler Attachment (Mounts to Ripper) - pair	1
3.	CR-B-06	CRM-00B006	Attachment Clamp Plate (Mounts to Ripper)	2
4.	CR-C	CRM-(00)C000	Crumbler Roller (Specify Size)	1
5.	CR-D	CRM-00D000	Pivot Pin	2
6.	CR-D-03	CRM-00D003	Pivot Pin Washer	2
7.	CR-E1	CRM-00E100	Safety Stand	2
8.	CR-E2	CRM-00E200	Safety Stand Sleeve (Mounts to Ripper)	2
9.	CR-E2-02	CRM-00E202	Safety Stand Clamp Plate (Mounts to Ripper)	2
10.	B4F-2438	GBR-39FL01	2-7/16" Four Bolt Flange Bearing	2
11.	FGZ-THD	GMB-ZERKTH	Threaded Grease Zerk	2
12.	FHP050X0425	GPN-0872HL	1/2" x 4-1/2" Handle Lock Hitch Pin	2
13.	FHB100X0800	CSNC516128	1" x 8" Gr. 5 Hex Bolt (for 5" Wide Ripper Rear Tube)	8
	FHB100X1000	CSNC516160	1" x 10" Gr. 5 Hex Bolt (for 7" Wide Ripper Rear Tube)	8
14.	FLW100	LWASHER-16	1" Lock Washer	8
15.	FHN100	HXNUT-16NC	1" Hex Nut	8
16.	FHB063X0250	CSNC510040	5/8" x 2-1/2" Gr. 5 Hex Bolt	8
17.	FLW063	LWASHER-10	5/8" Lock Washer	8
18.	FHN063	HXNUT-10NC	5/8" Hex Nut	8
19.	FHB050X0700	CSNC508112	1/2" x 7" Gr. 5 Hex Bolt (for 5" Wide Ripper Rear Tube)	8
	FHB050X0900	CSNC508144	1/2" x 9" Gr. 5 Hex Bolt (for 7" Wide Ripper Rear Tube)	8
20.	FHB050X0400	CSNC508064	1/2" x 4" Gr. 5 Hex Bolt	2
21.	FLW050	LWASHER-08	1/2" Lock Washer	10
22.	FHN050	HXNUT-08NC	1/2" Hex Nut	10



SERIAL NUMBER: _____

MODEL NUMBER: _____

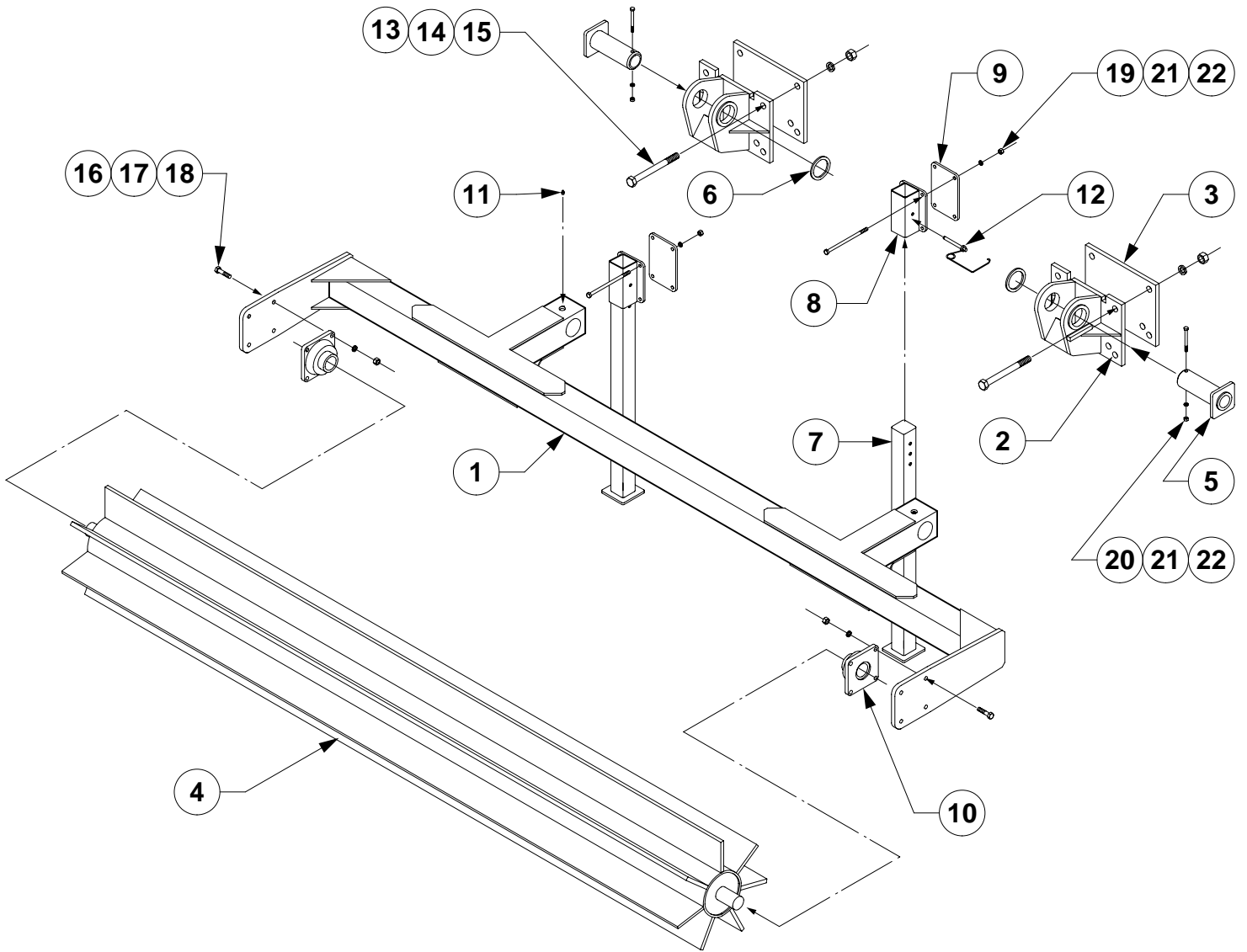



Ref.#	Old Part #	New Part #	Description	Q-ty per Unit
1	DPR-A	DPR-(00)A000	Roller Main Frame	1
2	DPR-B	DPR-00B000	Foot Attachment (pair)	1
3	DPR-B-07	DPR-00B007	Clamp Plate	2
4	DPR-C	DPR-00C000	Pivot Link (pair)	1
5	DPR-D	DPR-00D000	Turnbuckle Assembly - Acme Thread	2
6	DPR-E	DPR-(00)E000	Roller Tube (specify size)	1
7	DPR-E-06	DPR-00E006	Retaining Plate	4
8	DPR-E-10	GBR-39FL02	2-7/16" Severe Duty Bearing	2
9	DPR-F	DPR-00F000	Pivot Pin	2
10	DPR-F-03	DPR-00F003	Pivot Pin Washer	2
11	DPR-G-01	DPR-00G100	Turnbuckle Top Pin	2
12	DPR-G-02	DPR-00G200	Turnbuckle Bottom Pin	2
13	DPR-G-04	DPR-00G004	Turnbuckle Pin Washer	4
14	DPR-H	GPN-24A200	Safety Lockout Pin	2
15	DPR-J	DPR-00J000	Safety Stand	2
16	DPR-L	DPR-00L000	Scraper	varies
17	SR1628	DPR-16X28S	Star Ring 16" I.D. x 28" O.D.	varies
18	FHB125X1100	CSNC820176	1-1/4" x 11" Gr. 8 Hex Bolt	8
19	FHN125	HXNUT-20NC	1-1/4" Hex Nut	8
20	FLW125	LWASHER-20	1-1/4" Lock Washer	8
21	FHB050X0150	CSNC508024	1/2" x 1-1/2" Gr. 5 Hex Bolt	12
22	FHB075X0300	CSNC512040	3/4" x 2-1/2" Gr. 5 Hex Bolt	8
23	FHN075	HXNUT-12NC	3/4" Hex Nut	8
24	FLW075	LWASHER-12	3/4" Lock Washer	8
25	FHB063X0200	CSNC510032	5/8" x 2" Gr. 5 Hex Bolt	varies
26	FHN063	HXNUTJ10NC	5/8" Hex Jam Nut	varies
27	FHB020X0500	CSNC508072	1/2" x 4-1/2" Gr. 5 Hex Bolt	2
28	FHN050	HXNUT-08	1/2" Hex Nut	2
29	FLW050	LWASHER-08	1/2" Lock Washer	2
30	FHP050X0425	GPN-0872HL	1/2" x 4-1/2" Handle Lock Hitch Pin	4
31	FLP043X0150	GPN-070LYN	7/16" x 1-1/2" Lynch Pin	varies
32	FPP031X0275	GPN-0536PT	5/16" x 2-3/4" PTO Pin	6
33	FGZ-THD	GMB-ZERKTH	Threaded Grease Zerk	8



DOWN PRESSURE ROLLER

SERIAL NUMBER: _____

MODEL NUMBER: _____

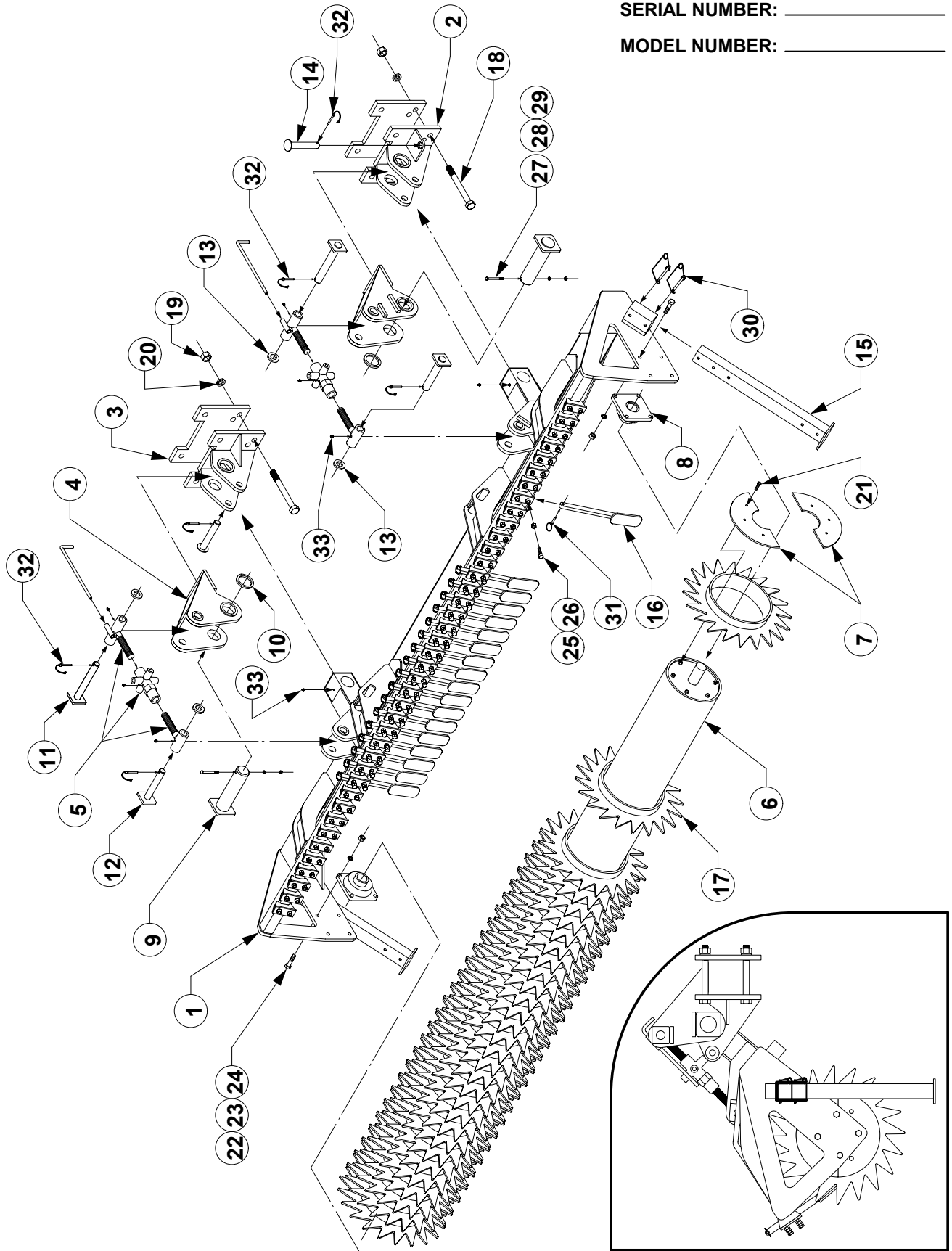

T.G. SCHMEISER CO., INC.

Limited Warranty Statement

T. G. Schmeiser Co., Inc. warrants each new Schmeiser® product to be free from defects in material and workmanship. This warranty is applicable only for the normal service life expectancy of the product or components, not to exceed twelve (12) consecutive months from the date of delivery of the new Schmeiser product to the original purchaser.

Genuine T. G. Schmeiser Co., Inc. replacement parts and components will be warranted for 90 days from date of purchase, or the remainder of the original equipment warranty period, whichever is longer.

Under no circumstances will it cover any merchandise or components thereof, which, in the opinion of the company, has been subjected to misuse, unauthorized modifications, alteration, an accident or if repairs have been made with parts other than those obtainable through T. G. Schmeiser Co., Inc.

The Company in no way warrants engines, batteries, cylinders, tires or other trade accessories since these items are warranted separately by their respective manufacturer. Expendable components such as points, shanks, blades, rings, bearings, teeth, and the like are excluded from this warranty.

Our obligation under this warranty shall be limited to repairing or replacing, free of charge to the original purchaser, any part that, in our judgment, shall show evidence of such defect, provided further that such part shall be returned within thirty (30) days from date of failure to T. G. Schmeiser Co., Inc., routed through the dealer and distributor from whom the purchase was made, transportation charges prepaid.

This warranty shall not be interpreted to render T. G. Schmeiser Co., Inc. liable for injury or damages of any kind or nature to person or property. This warranty does not extend to the loss of crops, loss because of delay in harvesting, or any expense or loss incurred for labor, substitute machinery, rental or for any other reason.

Except as set forth above, **T. G. Schmeiser Co., Inc. shall have no obligation or liability of any kind on account of any of its equipment and shall not be liable for special or consequential damages. T. G. Schmeiser Co., Inc. makes no other warranty, expressed or implied, and, specifically, T. G. Schmeiser Co., Inc. disclaims any implied warranty or merchantability or fitness for a particular purpose. Some states or provinces do not permit limitations or exclusions of implied warranties or incidental or consequential damages, so the limitations or exclusion in this warranty may not apply.**

This warranty is subject to any existing conditions of supply, which may directly affect our ability to obtain materials or manufacture replacement parts.

T. G. Schmeiser Co., Inc. reserves the right to make improvements in design or changes in specifications at any time, without incurring any obligation to owners of units previously sold.

No one is authorized to alter, modify or enlarge this warranty nor the exclusion, limitations and reservations.

**WARRANTY VOID IF NOT REGISTERED
WITHIN 30 DAYS OF PURCHASE DATE**

Notes

A large rectangular box with a black border, containing 18 horizontal gray bars for writing notes. The bars are arranged in a repeating pattern of a gray bar followed by a white bar, starting from the top and ending at the bottom. The gray bars are intended for writing text.